

## SOLENOID VALVES

4707 Massachusetts Ave. - P.O. Box 18128  
 Indianapolis, Indiana 46218-0128  
 Ph: 1-800-63 GOULD   Fx: (317) 547-5234  
 Web: <http://www.gouldvalve.com>  
 E-mail: [gouldvalve@gouldvalve.com](mailto:gouldvalve@gouldvalve.com)

**1/8"-2" NPT  
 TYPES K, KX,  
 KR, & KRX**

2-WAY – INVESTMENT CAST CF8M BODIES - PACKLESS  
 VELVETROL® INTERNAL PISTON PILOT OPERATED  
 GENERAL PURPOSE SOLENOID VALVES - FULL PORT  
 NORMALLY CLOSED OR NORMALLY OPEN

- ★ FOR: GENERAL SERVICE-AIR-WATER-STEAM-INERT GASES  
 CORROSIVE FLUIDS (CONSULT FACTORY)
- ★ PRESSURES: 5 PSI DIFFERENTIAL MINIMUM TO 1000 PSI MAXIMUM
- ★ TEMPERATURE: -360°F TO 450°F. CLASS F OR N COILS
- ★ MOUNTING: INSTALL IN HORIZONTAL LINE WITH COIL UPRIGHT AND ON TOP



### SIZES 1/8" - 2" NPT FULL PORT

★ <b>SERVICE RATINGS</b>	Complete Pricing, Service & Electrical Ratings shown in Price Schedule. Valves will be furnished for 5-150 PSI and 120 VAC Unless Otherwise Specified.	
NORMALLY CLOSED--		--NORMALLY OPEN
<b>TYPE K TYPE K-3T</b>	5-150, 10-300 PSI; 300°F. MAX. FLUID, CLASS F STANDARD COILS: 120, 240, 480 VAC 60 Hz, 14W MAX. NON-STANDARD COILS AVAILABLE WITH VOLTAGE, WATTAGE, AND LEAD WIRE LENGTH TO YOUR SPECS.	<b>TYPE KR TYPE KR-3T</b>
<b>TYPE KS</b>	FOR LIQUIDS TO 700 PSI, NON-VOLATILE INERT GASES TO 400 PSI. TEMPERATURE TO 300°F	<b>N/A</b>
<b>TYPE KST</b>	FOR LIQUIDS TO 1000 PSI, TEMPERATURE TO 300°F	<b>N/A</b>
<b>TYPE KX</b>	SIMILAR TO TYPE K, EXCEPT 5-60 OR 5-150 PSI AND ALL WETTED PARTS ARE 316 SS OR PTFE (TEFLON®)	<b>TYPE KRX</b>
<b>TYPE KX-3EP-EP-62</b>	SPECIAL CONSTRUCTION FOR DEIONIZED WATER SERVICE – ETHYLENE PROPYLENE SEALS AND ALL WELDS PASSIVATED.	<b>TYPE KRX-3EP-EP-62</b>
<b>TYPE KXS</b>	SIMILAR TO KX EXCEPT 10-300 PSI (Norm. Open to 150 PSI)	<b>TYPE KRX</b>
<b>ADD -1</b>	HIGH TEMP. (CLASS N) COILS - FLUID TEMP. TO 450°F. 200 PSI STEAM.	<b>ADD -1</b>
<b>ADD -2</b>	EXPLOSION PROOF COIL HOUSING - NEMA 7	<b>ADD -2</b>
<b>ADD -3B, -3EP -3T, -3V</b>	LEAKPROOF PILOT SEAT: -3B (BUNA), -3EP ETHYLENE- PROPYLENE, -3T (TEFLON®) PTFE, -3V (VITON®) FLUOROCARBON	<b>ADD -3B, -3EP -3T, -3V</b>
<b>ADD -24</b>	WATER TIGHT, EXPLOSION PROOF COIL HOUSING. NEMA 4 & 7	<b>ADD -24</b>
<b>ADD -25</b>	DUST TIGHT, EXPLOSION PROOF COIL HOUSING. NEMA 5 & 7	<b>ADD -25</b>
<b>ADD -57</b>	MANUAL RESET – SAFETY SHUT-OFF, NO VOLTAGE RELEASE. SEE BULLETIN -57	<b>ADD -57</b>
<b>ADD -81, -84</b>	-81 SLOW CLOSE (REDUCES WATER HAMMER) -84 QUICK CLOSE (BOTH FACTORY SETUPS)	<b>ADD -81, -84</b>
<b>ADD -230</b>	SPECIAL CONSTRUCTION FOR GASOLINE AND DIESEL FUEL. SEE BULLETIN 230-K	<b>ADD -230</b>
<b>ADD -SW,</b>	PIPE CONNECTION: -SW SOCKET WELD	<b>ADD -SW</b>

★ CONSTRUCTION:

**Type K & KX:** CLASS F & N COILS are Waterproof, Fungusproof, Molded of Filled Polyester with 18" Leads. BODIES are Investment Cast in CF8M Stainless Steel. PISTON SPRINGS are 316 or 302 SS.

**Type K:** BONNET ASSEMBLIES are 304 SS TUBES welded to 303 SS BONNET and 303 SS TUBE PLUG. PISTON ASSEMBLIES are 303 SS with Glass & Moly Filled PTFE PISTON RINGS and 316 SS EXPANDERS. SEAT DISCS are Buna, EP, Fluorocarbon, and Virgin PTFE. PILOT ASSEMBLIES are 416 SS ARMATURE with a 316 SS PILOT POINT and 316 SS PINS.

**Type KX:** BONNET ASSEMBLIES are 316 SS TUBES welded to 316 SS BONNET and 316 SS TUBE PLUG. PISTON ASSEMBLIES are 316 SS with Glass & Moly Filled PTFE PISTON RINGS and 316 SS EXPANDERS. SEAT DISCS are Virgin PTFE. PILOT ASSEMBLIES are 316 SS JACKET welded over plain carbon steel CORE.

1/8"-1" GLOBE STYLE BODY WITH UNION BONNET  
 1-1/4"-2" GLOBE STYLE BODY WITH BOLT-DOWN BONNET

See Price Schedule for "Terms and Conditions of Sale."

## PERFORMANCE, ORDERING AND INSTALLATION GUIDE

**ORDERING DATA**--SPECIFY PIPE SIZE, TYPE, FLUID, OPERATING PRESSURE, TEMPERATURE RANGE, ELECTRICAL SPECIFICATIONS, BACK PRESSURE (IF ANY).

**FLOW CHARACTERISTICS**--SEE FLOW CURVES IN BULLETIN 5-FL, OR Cv FACTORS LISTED BELOW AND IN BULLETIN CP-1.

**OPERATION**--PISTON PILOT OPERATED. MINIMUM PRESSURE DROP OF 5 PSI ( $\Delta P$ ) IS REQUIRED ACROSS VALVE FOR OPERATION.

**MOUNTING**--MOUNT IN HORIZONTAL LINE WITH COIL VERTICAL AND ON TOP. INSTALL 40 MESH STRAINER (NOT LARGER) AHEAD OF VALVE. CHECK FOR PROPER COIL VOLTAGE. MAKE SURE THAT THE FLOW ARROW ON VALVE BODY IS POINTING IN THE DIRECTION OF FLOW.

**OPERATING PRESSURE:** THE SOLENOID VALVE SHOULD BE ORDERED WITH **THE MAXIMUM RATED PRESSURE CLOSEST TO THE ACTUAL PRESSURE THE VALVE WILL OPERATE IN.** FOR EXAMPLE: IF YOUR APPLICATION IS FOR 40 PSI, ORDER A VALVE RATED 5-150 PSI **NOT** 10-400 PSI.

**SERVICING**--SOLENOID VALVES SHOULD BE FREQUENTLY CHECKED FOR OPERATION, CLEANLINESS, & INTERNAL WEAR - REPAIR KITS ARE FACTORY AVAILABLE --GIVE SIZE, TYPE, SERIAL NUMBER OR OPERATING DATA (VOLTAGE, PRESSURE, ETC.)

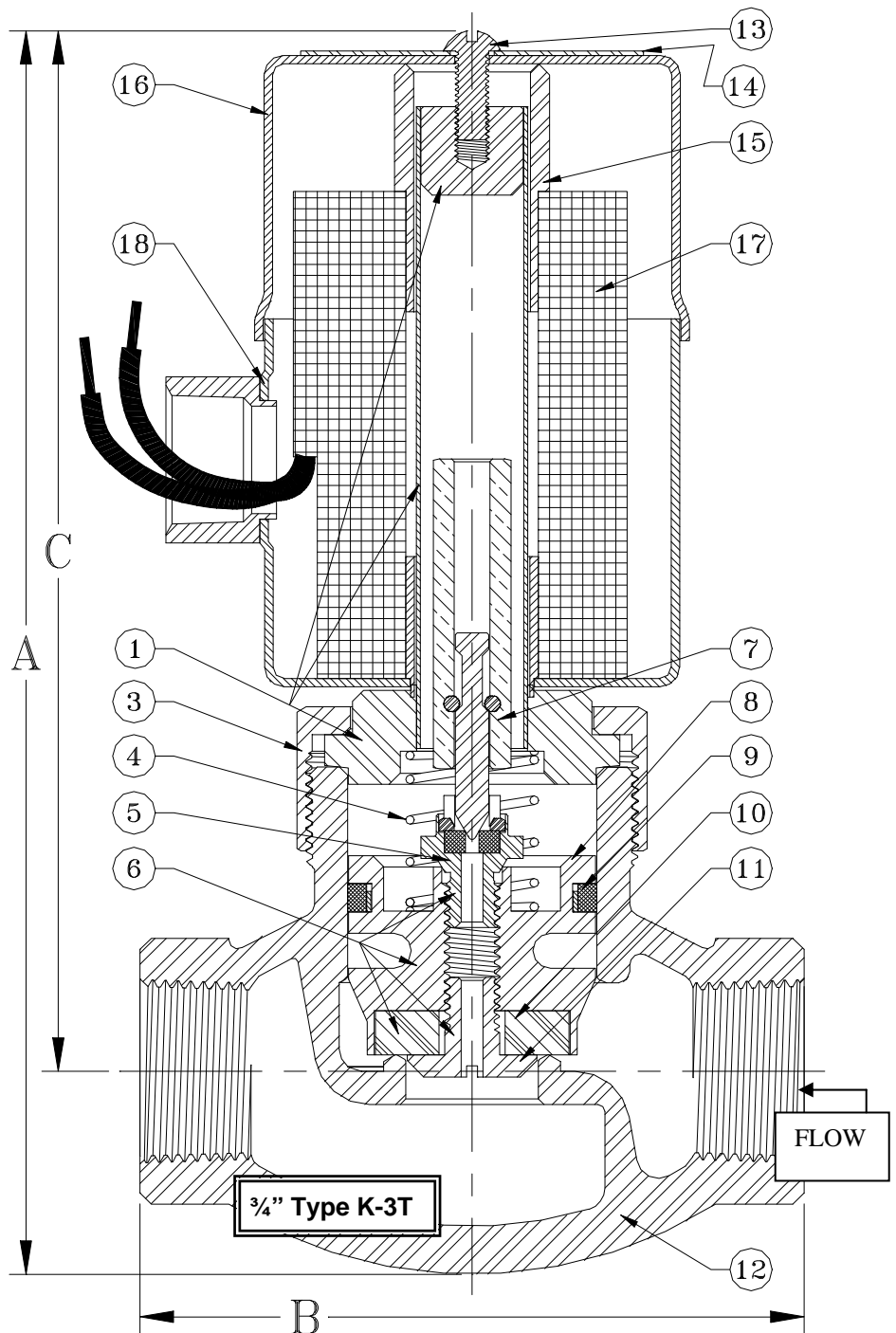

Valve Size	1		1a		2	3	4	5		6		7		7a		8		9	10	11	
	N.C. Bonnet Assembly	N.O. Bonnet Assembly	Bonnet Bolts	Bonnet Ring	Piston Spring	Seat Screw	Piston Assembly	N.C. Pilot Assembly	N.O. Pilot Assembly	Piston Only	Piston Ring & Expander	Seat Disc	Guide Nut or Disc Screw								
	K	KX	KR	KRX	ALL	ALL	ALL	K/KR	KX/KRX	K/KR	KX/KRX	K	KX	KR	KRX	K/KR	KX/KRX	ALL	ALL	K/KR	KX/KRX
1/8	190	190316	190R	190R316	N/A	192	37-14	415-x2x	415-x3x	853	8531	21-1	2421	32R1K	242R4	402-2	402-3	57	36-12x	851	406S
1/4	190	190316	190R	190R316	N/A	192	37-14	415-x2x	415-x3x	853	8531	21-1	2421	32R1K	242R4	402-2	402-3	57	36-12x	851	406S
3/8	190	190316	190R	190R316	N/A	192	37-14	415-x2x	415-x3x	853	8531	21-1	2421	32R1K	242R4	402-2	402-3	57	36-12x	851	406S
1/2	190	190316	190R	190R316	N/A	192	37-14	31-x-303	31x316	187	187316	21-1	2421	32R1K	242R4	187	187316	189	36-12x	188	188316
3/4	197	197316	197R	197R316	N/A	199	37-14	31-x-303	31x316	194	194316	21-1	2421	32R1K	242R4	194	194316	196	36-34x	195	195316
1	204	204316	204R	204R316	N/A	206	37-14	31-x-303	31x316	201	201316	21-1	2421	32R1K	242R4	201	201316	203	36-1x	202	202
1-1/4	218	218316	218R	218R316	9-18	N/A	37-2	31-x-303	31x316	214	214316	22-1	2422	32R1K	242R6	214	214	216	36-112x	215	215
1-1/2	218	218316	218R	218R316	9-18	N/A	37-2	31-x-303	31x316	214	214316	22-1	2422	32R1K	242R6	214	214	216	36-112x	215	215
2	224	224316	224R	224R316	9-19	N/A	37-2	31-x-303	31x316	220	220316	22-1	2422	32R1K	242R6	220	220	222	36-2x	221	221

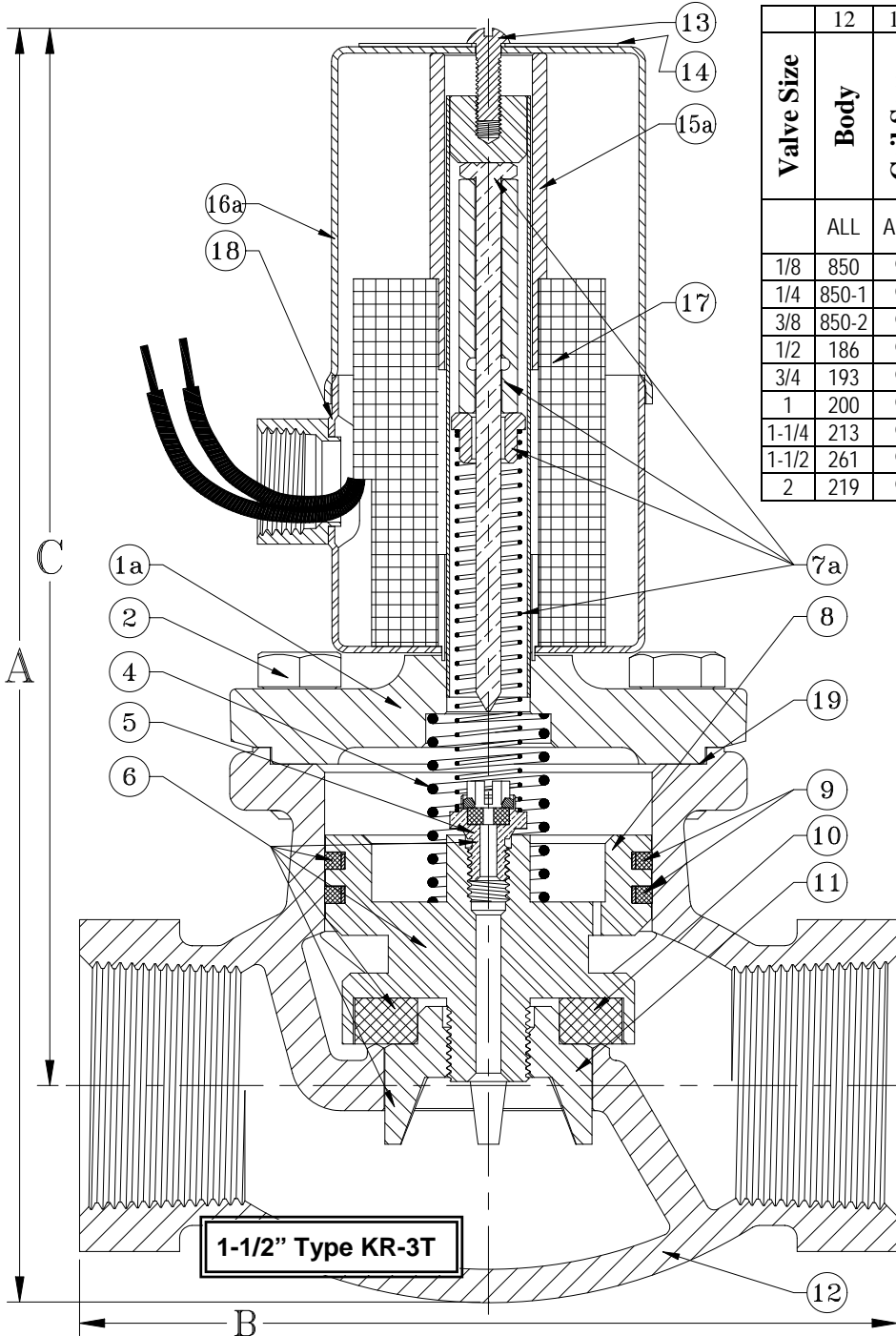

Valve Size	12	13	14	15	15a	16	16a	17	18	19
	Body	Coil Screw	Nameplate	N.C. Nip	N.O. Nip	N.C. Coil Cover	N.O. Coil Cover	Coil	Coil Can	Bonnet Seal
	ALL	ALL	ALL	K/KX	KR KRX	K/KX	KR KRX	ALL	K/KX	ALL
1/8	850	9	44-1-1	1152	1153	89	89NO	Consult	87	N/A
1/4	850-1	9	44-1-1	1152	1153	89	89NO	Factory or List Price Schedule	87	N/A
3/8	850-2	9	44-1-1	1152	1153	89	89NO		87	N/A
1/2	186	9	44-1-1	1152	1153	89	89NO		87	N/A
3/4	193	9	44-1-1	1152	1153	89	89NO		87	N/A
1	200	9	44-1-1	1152	1153	89	89NO		87	N/A
1-1/4	213	9	44-1-1	1152	1153	89	89NO	87	2-151	
1-1/2	261	9	44-1-1	1152	1153	89	89NO	87	2-151	
2	219	9	44-1-1	1152	1153	89	89NO	87	2-154	

Valve Size	CV Factor	Valve Dimensions							
		N. C.				N. O.			
		A	B	C	wt lbs	A	B	C	wt lbs
1/8	1.1	6.03	2.63	5.34	3	7.03	2.63	6.34	4
1/4	2.1	6.03	2.63	5.34	3	7.03	2.63	6.34	4
3/8	3.2	6.03	2.63	5.34	3	7.03	2.63	6.34	4
1/2	3.9	6.75	3.13	5.88	4	7.75	3.13	6.88	4
3/4	7.5	7.02	3.75	5.88	4	8.02	3.75	6.88	5
1	9.9	7.44	4.16	6.19	5	8.44	4.16	7.19	5
1-1/4	23.0	8.56	6.13	6.94	11	9.56	6.13	7.94	12
1-1/2	25.0	8.56	6.13	6.94	11	9.56	6.13	7.94	12
2	45.0	9.38	6.45	7.39	17	10.38	6.45	8.39	17

Valve Size	1b N.C. XP Bonnet Assembly		1c N.O. XP Bonnet Assembly		7b N.C. XP Pilot Assembly		7c N.O. XP Pilot Assembly		20 Coil Endplates	21 Coil Spring	22 N.C. XP Cover N.O. XP Cover		23 XP Bolts XP Washers		24 XP Base
	K2	KX2	KR2	KRX2	K2	KX2	KR2	KRX2	K2/KX2 KR2/KRX2	K2/KX2 KR2/KRX2	K2 KX2	KR2 KRX2	K2/KX2 KR2/KRX2	K2/KX2 KR2/KRX2	K2/KX2 KR2/KRX2
1/8	190XP	190XP316	190RXP	190RXP316	25-1	2421	P32R6K	242R8	113	37-2	42NC	42NO	9-4	46-3	41A
1/4	190XP	190XP316	190RXP	190RXP316	25-1	2421	P32R6K	242R8	113	37-2	42NC	42NO	9-4	46-3	41A
3/8	190XP	190XP316	190RXP	190RXP316	25-1	2421	P32R6K	242R8	113	37-2	42NC	42NO	9-4	46-3	41A
1/2	190XP	190XP316	190RXP	190RXP316	25-1	2421	P32R6K	242R8	113	37-2	42NC	42NO	9-4	46-3	41A
3/4	197XP	197XP316	197RXP	197RXP316	25-1	2421	P32R6K	242R8	113	37-2	42NC	42NO	9-4	46-3	41A
1	204XP	204XP316	204RXP	204RXP316	25-1	2421	P32R6K	242R8	113	37-2	42NC	42NO	9-4	46-3	41A
1-1/4	218XP	218XP316	218RXP	218RXP316	22-1	2422	P32R6K	242R10	113	37-2	42NC	42NO	9-4	46-3	41A
1-1/2	218XP	218XP316	218RXP	218RXP316	22-1	2422	P32R6K	242R10	113	37-2	42NC	42NO	9-4	46-3	41A
2	224XP	224XP316	224RXP	224RXP316	22-1	2422	P32R6K	242R10	113	37-2	42NC	42NO	9-4	46-3	41A

size	A	B	C	wt
1/8	6.56	2.63	5.88	7
1/4	6.56	2.63	5.88	7
3/8	6.56	2.63	5.88	7
1/2	7.30	3.13	6.44	7
3/4	7.56	3.75	6.44	8
1	8.00	4.16	6.75	9
1-1/4	9.10	6.13	7.50	15
1-1/2	9.10	6.13	7.50	15
2	9.92	6.45	7.94	20

The Explosion proof housing is constructed of two (2) machined, enamel painted sand-cast gray iron parts bolted together, threaded onto the bonnet assembly and rigidly cemented in place. Once assembled the housing will **not** rotate. NEMA 4, NEMA 5, or NEMA 7 ratings are available with this housing.

size	A	B	C	wt
1/8	7.69	2.63	7.00	8
1/4	7.69	2.63	7.00	8
3/8	7.69	2.63	7.00	8
1/2	8.41	3.13	7.54	8
3/4	8.68	3.75	7.54	9
1	9.10	4.16	7.85	10
1-1/4	10.22	6.13	8.60	16
1-1/2	10.22	6.13	8.60	16
2	11.04	6.45	9.05	21

